

POWERTEC® 205C, 255C, 305C

Spare Parts – POWERTEC® 205C	1
Figure A: Machine Assembly - POWERTEC® 205C	2
Figure B: Machine Assembly - POWERTEC® 205C	4
Figure C: Wire Drive Assembly - POWERTEC® 205C	5
Miscellaneous Items (not shown in figure A, B, C) - POWERTEC® 205C	5
Spare Parts – POWERTEC® 255C & 305C	6
Figure D: Machine Assembly - POWERTEC® 255C & 305C	6
Figure E: Machine Assembly - POWERTEC® 255C & 305C	9
Figure F, G: Wire Drive Assembly – POWERTEC® 255C & 305C	11
Miscellaneous Items (not shown in figure D, E, F, G)	11
Electrical Schematic	12
WEEE	16



Spare Parts – POWERTEC® 205C

SP50234/50235 REV02
12/05

ASSEMBLY PAGE NAME			Machine Assembly	Machine Assembly	Wire Drive Assembly	Miscellaneous Items			
CODE NO.:	K NO.:	FIGURE NO.:	A	B	C	-			
50234	K14054-1	POWERTEC® 205C 400V	1	1	1	1			
50235	K14054-2	POWERTEC® 205C 230/400V	2	2	2	2			

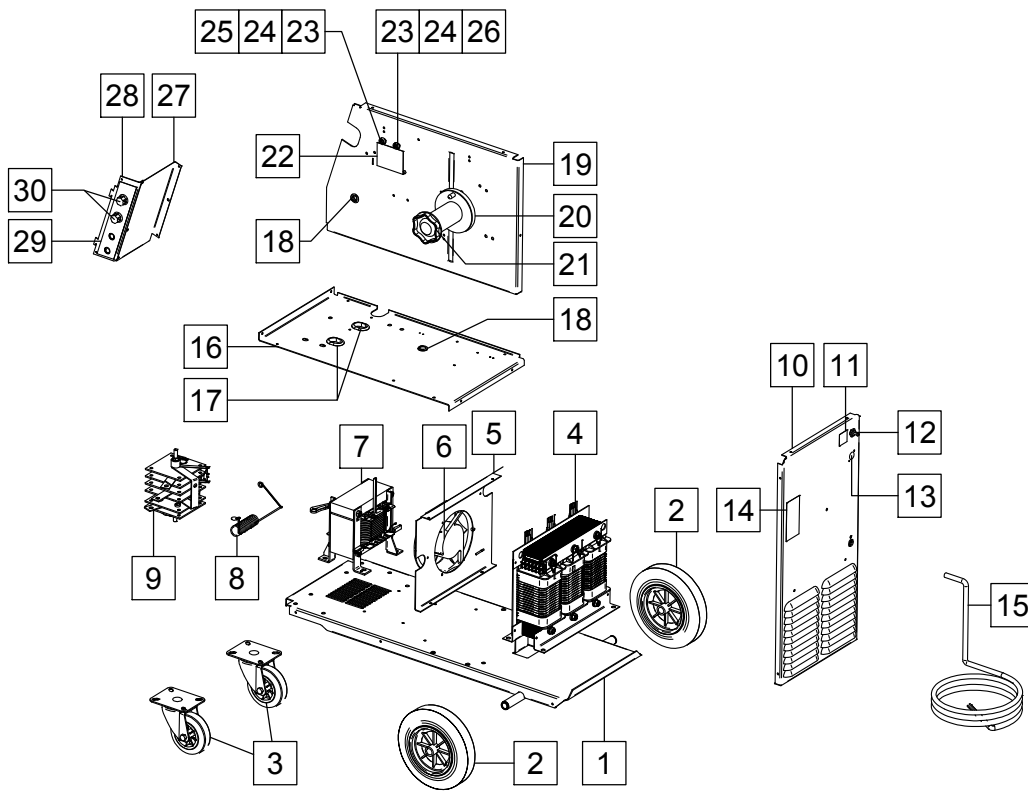

Figure A

Figure A: Machine Assembly - POWERTEC® 205C

Item	Description	Part Number	QTY	1	2	3	4	5	6	7
1	BASE	R-3019-121-2/08R	1	•	•					
2	REAR WHEELS	1029-660-201R	2	•	•					
3	FRONT WHEELS	1029-660-101R	2	•	•					
4	TRANSFORMER T1	R-4034-096-1R	1	•	-					
	TRANSFORMER T1	R-4034-080-1R	1	-	•					
5	FAN SUPPORT	R-1019-204-1/08R	1	•	•					
6	FAN	0873-100-031R	1	•	•					
7	CHOKE L1	R-4034-089-1R	1	•	•					
8	RESISTOR R1	R-0010-308-1R	1	•	•					
9	RECTIFIER V1	R-0010-309-1R	1	•	•					
	THERMAL SENSOR 80°C	1115-769-003R	1	•	•					
	THERMAL SENSOR 115°C	1115-769-012R	1	•	•					
10	REAR PANEL	R-1012-202-4/08R	1	•	•					
11	STICKER (GAS CONNECTION)	2719-107-733R	1	•	•					
12	GAS SOLENOID	0972-423-005R	1	•	•					
13	HOLE PLUG	1361-599-058R	1	•	•					
14	STICKER (GAS CYLINDER HEIGHT)	R-7040-228-3R	1	•	•					
15	POWER LEAD	R-5041-164-1R	1	•	•					
16	SHELF	R-3019-123-3/08R	1	•	•					
17	RUBBER CABLE BUSH	1373-111-331R	2	•	•					
18	RUBBER CABLE BUSH	1373-182-002R	3	•	•					
19	DIVIDER	R-3019-201-1/08R	1	•	•					
20	REEL HUB STANDARD	0744-000-192R	1	•	•					
21	PLASIC NUT	B11035-1	1	•	•					
22	STICKER	R-0010-276-1R	1	•	•					
23	FUSE SOCKET	1158-632-032R	2	•	•					
24	FUSE CAP	1158-632-033R	2	•	•					
25	FUSE F1	1158-660-010R	1	•	•					
26	FUSE F2	1158-660-008R	1	•	•					
27	SHIELD	R-1019-197-1/08R	1	•	•					
28	SHIELD	R-1019-186-1/08R	1	•	•					
29	STICKER	R-0010-280-1R	1	•	•					
30	KNOBS	9ET13639-3R	2	•	•					

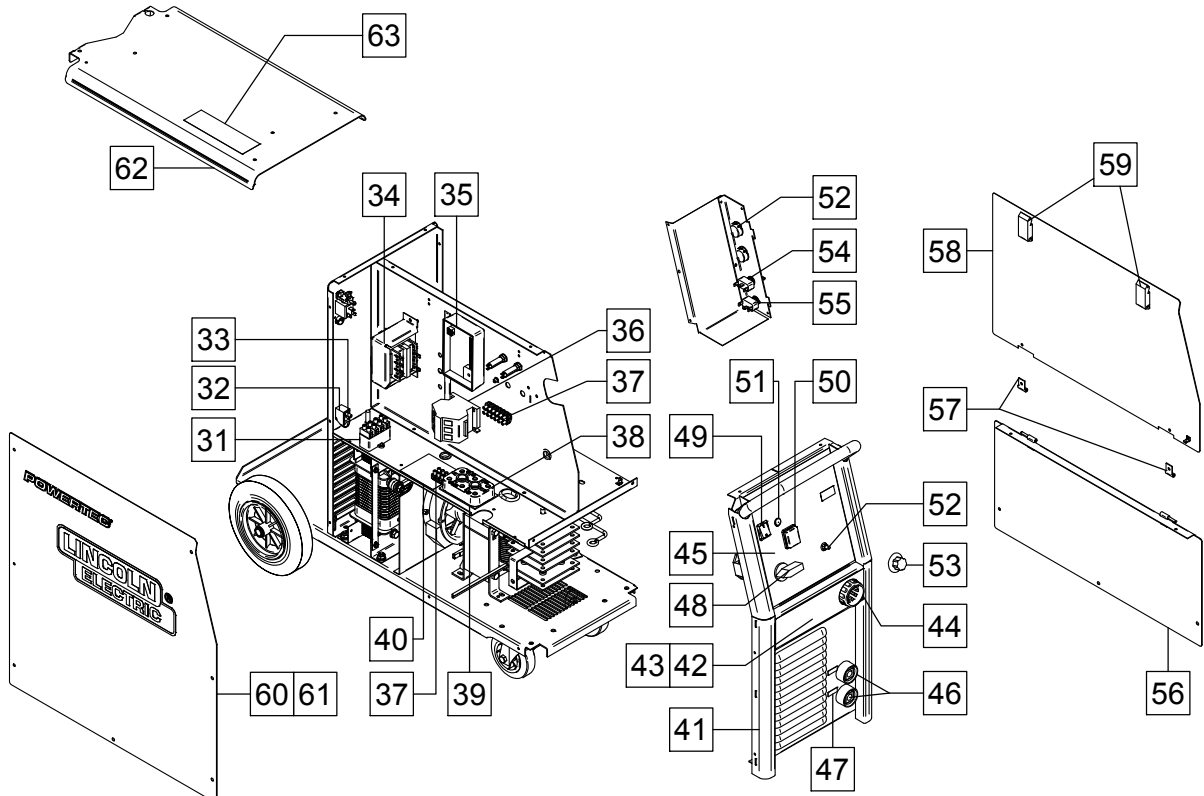

Figure B.

Figure B: Machine Assembly - POWERTEC® 205C

Item	Description	Part Number	QTY	1	2	3	4	5	6	7
31	FILTER RC	0874-400-011R	1	•	•					
32	CLAMP	1361-599-398R	1	•	•					
33	CABLE RELEIF	1361-599-399R	1	•	•					
34	TRANSFORMER T2	C-4244-374-2R	1	•	•					
35	P.C. BOARD	Y024-4R	1	•	•					
36	CONTACTOR K1	1115-212-207R	1	•	-					
	CONTACTOR K1	1115-212-220R	1	-	•					
37	TERMINAL BLOCK X13	1131-990-005R	6	•	-					
	TERMINAL BLOCK X12, X13	1131-990-005R	9	-	•					
38	TERMINAL BLOCK X11	1361-599-255R	1	-	•					
39	PLATE	D-2731-731-1R	1	-	•					
40	STICKER (230/400V)	R-0010-221-1R	1	-	•					
41	FRONT PANEL	R-3019-120-4/08R	1	•	•					
42	SHIELD	R-1019-221-1/02R	1	•	•					
43	STICKER (NAME PRODUCT)	R-0010-266-1R	1	•	•					
44	EURO SLEEVE	1361-599-708R	1	•	•					
45	STICKER (FRONT PANEL)	R-0010-263-1R	1	•	•					
46	SOCKETS X2, X3	C-2986-001-2R	2	•	•					
47	STICKER	2719-107-053R	1	•	•					
48	SWITCH S1	1115-260-168R	1	•	•					
49	SWITCH S3	1115-270-005R	1	•	•					
50	BLACK FLAME SHIELD	1115-299-073R	1	•	•					
51	LAMP H1	0917-421-024R	1	•	•					
52	POTENTIOMETER R11,R12, R13	1158-113-304R	3	•	•					
53	KNOB	9ET10491R	1	•	•					
54	SWITCH S11	1115-280-005R	1	•	•					
55	SWITCH S12	1115-280-004R	1	•	•					
56	RIGHT SIDE PANEL	R-3019-122-1/02R	1	•	•					
57	HINGLES	D-2541-004-2/02R	2	•	•					
58	WIRE DRIVE DOOR	R-1019-190-1R	1	•	•					
59	LOCKS	0654-610-004R	2	•	•					
60	LEFT SIDE PANEL	R-1019-189-1R	1	•	•					
61	STICKER (WIRING DIAGRAM)	R-0010-264-1R	1	•	-					
	STICKER (WIRING DIAGRAM)	R-0010-265-1R	1	-	•					
62	COVER	R-1012-209-2/02R	1	•	•					
63	STICKER (WARNING)	2719-107-728R	1	•	•					

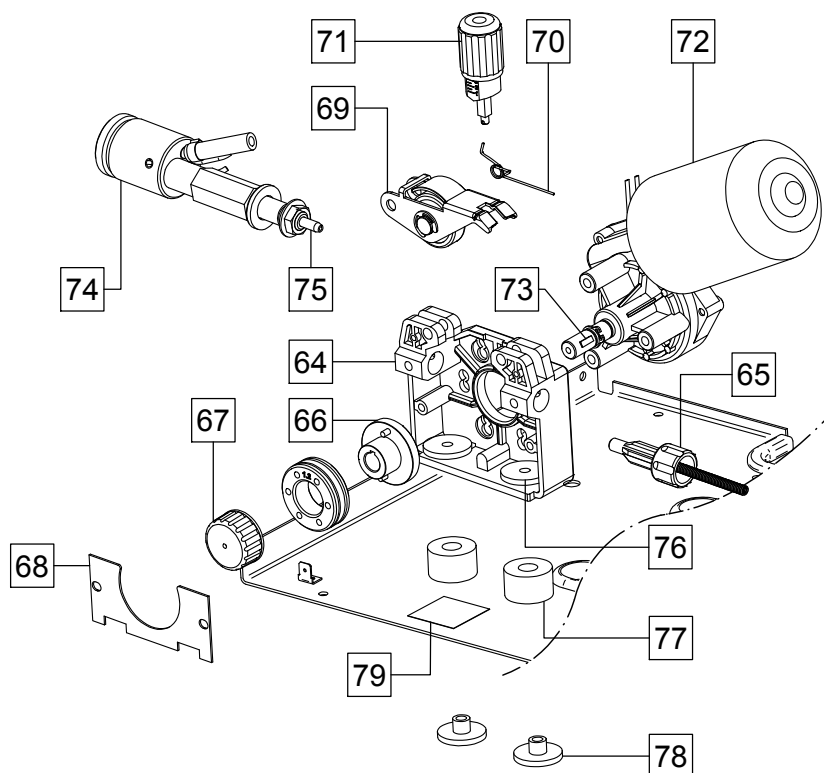

Figure C

Figure C: Wire Drive Assembly - POWERTEC® 205C

Item	Description	Part Number	QTY	1	2	3	4	5	6	7
	WIRE DRIVE ASSEMBLY	0744-000-160R	1	•	•					
64	FEED PLATE	0744-000-219R	1	•	•					
65	INLET GUIDE	0744-000-224R	1	•	•					
66	ADAPTER	0744-000-227R	1	•	•					
67	FIXING CAP	0744-000-216R	1	•	•					
68	METAL COVER	0744-000-218R	1	•	•					
69	PRESSURE ARM COMPL.	0744-000-221R	1	•	•					
70	SPRING PRESSURE ARM	0744-000-220R	1	•	•					
71	FIXING ARM COMPL.	0744-000-223R	1	•	•					
72	MOTOR	0744-000-229R	1	•	•					
73	WOODROF KEY	0646-231-102R	1	•	•					
74	EURO SOCKET COMPLETE	R-8040-042-2R	1	•	•					
75	OUTLET GUIDE	R-2010-006-1R	1	•	•					
76	SLEEVES	1361-599-564R	2	•	•					
77	SLEEVES	1361-599-565R	2	•	•					
78	SLEEVES	1361-599-720R	2	•	•					
79	STICKER	2719-107-732R	1	•	•					

Miscellaneous Items (not shown in figure A, B, C) - POWERTEC® 205C

Item	Description	Part Number	QTY	1	2	3	4	5	6	7
80	WIRING HARNESS (PRIMARY)	R-5041-165-1R	1	•	-					
81	WIRING HARNESS (PRIMARY)	R-5041-165-2R	1	-	•					
82	WIRING HARNESS (SECONDARY)	R-5041-166-1R	1	•	•					
83	WIRING HARNESS	R-5041-175-1R	1	•	•					
84	PE LEAD	R-5041-101-1R	1	•	•					

Spare Parts – POWERTEC® 255C & 305C

SP50236/50237/50238/50239/50240/50241 REV02
12/05

ASSEMBLY PAGE NAME			Machine Assembly	Machine Assembly	Wire Drive Assembly	Wire Drive Assembly	Miscellaneous Items		
CODE NO.:	K NO.:	FIGURE NO.:	D	E	F	G	-		
50236	K14055-1	POWERTEC® 255C 400V	1	1	1	1	1		
50237	K14055-2	POWERTEC® 255C 230/400V	2	2	2	2	2		
50238	K14056-1	POWERTEC® 305C 400V	3	3	3	3	3		
50239	K14056-2	POWERTEC® 305C 230/400V	4	4	4	4	4		
50240	K14056-3	POWERTEC® 305C 400V	5	5	5	5	5		
50241	K14056-4	POWERTEC® 305C 230/400V	6	6	6	6	6		

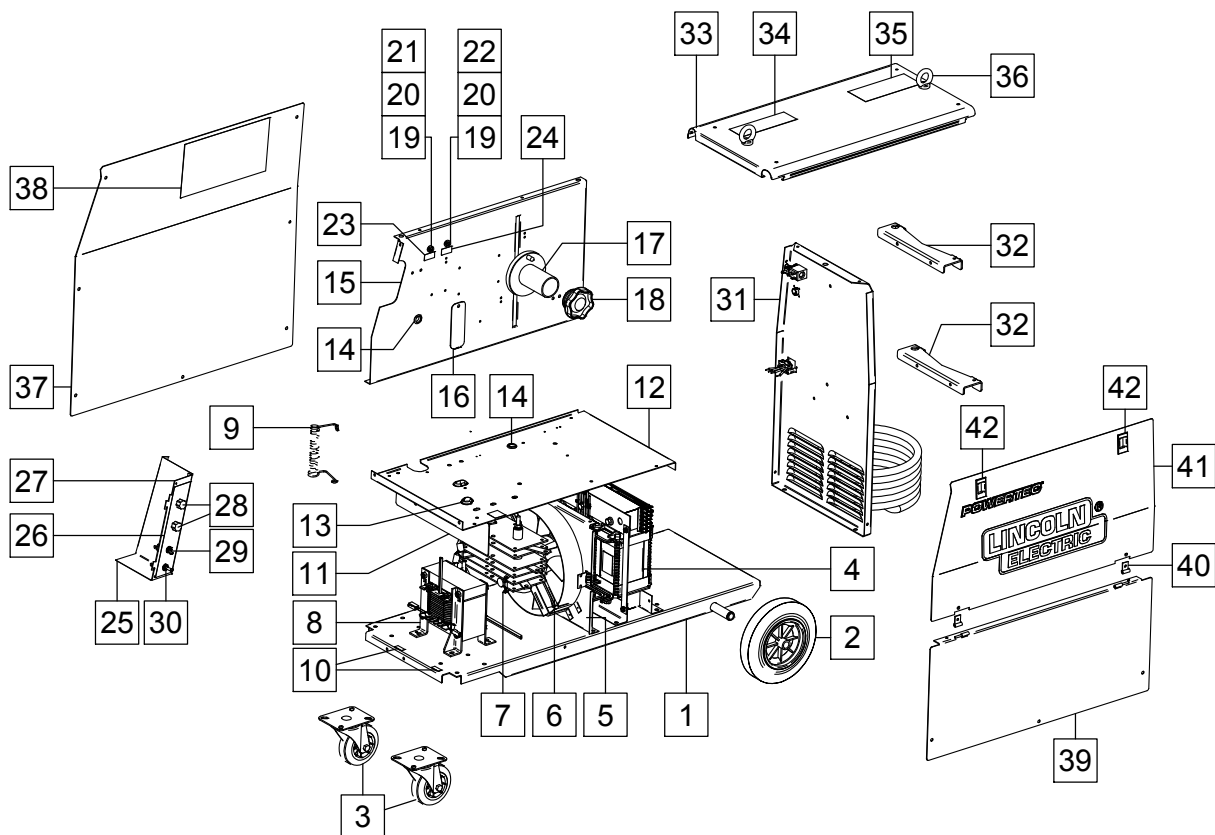

Figure D

Figure D: Machine Assembly - POWERTEC® 255C & 305C

Item	Description	Part Number	QTY	1	2	3	4	5	6	7
1	BASE	R-3019-179-1/08R	1	●	●	●	●	●	●	
2	REAR WHEELS	1029-660-201R	2	●	●	●	●	●	●	
3	FRONT WHEELS	1029-660-101R	2	●	●	●	●	●	●	
4	TRANSFORMER T1	R-4034-082-1R	1	●	●	-	-	-	-	
	TRANSFORMER T1	R-4034-083-1R	1	-	-	●	●	●	●	
5	FAN SUPPORT	R-1019-201-1/08R	1	●	●	-	-	-	-	
	FAN SUPPORT	R-3019-183-1/08R	1	-	-	●	●	●	●	
6	FAN	0873-100-031R	1	●	●	-	-	-	-	
	FAN	R-8040-255-1R	1	-	-	●	●	●	●	

7	RECTIFIER V1	R-0010-294-1R	1	●	●	-	-	-	-	
	RECTIFIER V1	R-0010-295-1R	1	-	-	●	●	●	●	
	THERMAL SENSOR 80°C	1115-769-003R	1	●	●	●	●	●	●	
	THERMAL SENSOR 115°C	1115-769-012R	1	●	●	●	●	●	●	
8	CHOKE L1	R-4034-089-1R	1	●	●	●	●	●	●	
	THERMAL SENSOR 65°C	1115-769-053R	1	●	●	●	●	●	●	
	THERMAL SENSOR 140°C	1115-769-013R	1	●	●	●	●	●	●	
9	RESISTOR R1	R-0010-116-3R	1	●	●	●	●	●	●	
10	STICKER	2719-107-769R	1	●	●	●	●	●	●	
11	SHIELD	R-1019-220-1/08R	1	●	●	●	●	●	●	
12	SHELF	R-3019-181-1/08R	1	●	●	●	●	●	●	
13	RUBBER CABLE BUSH	1373-111-331R	1	●	●	●	●	●	●	
14	RUBBER CABLE BUSH	1373-182-002R	1	●	●	●	●	●	●	
15	DIVIDER	R-3019-182-1/08R	1	●	●	●	●	●	●	
16	SHIELD	R-1019-202-1/08R	1	●	●	●	●	●	●	
17	REEL HUB STANDARD	0744-000-192R	1	●	●	●	●	●	●	
18	PLASIC NUT	B11035-1	1	●	●	●	●	●	●	
19	FUSE SOCKET	1158-632-032R	2	●	●	●	●	●	●	
20	FUSE CAP	1158-632-033R	2	●	●	●	●	●	●	
21	FUSE F1	1158-660-010R	1	●	●	●	●	●	●	
22	FUSE F2	1158-660-008R	1	●	●	●	●	●	●	
23	STICKER F1	2719-107-193R	1	●	●	●	●	●	●	
24	STICKER F2	2719-107-111R	1	●	●	●	●	●	●	
25	SHIELD	R-1019-186-1/08R	1	●	●	●	●	●	●	
26	STICKER	R-0010-280-1R	1	●	●	●	●	●	●	
27	SHIELD	R-1019-203-1/08R	1	●	●	●	●	●	●	
28	KNOBS	9ET13639-3R	2	●	●	●	●	●	●	
29	SWITCH S11	1115-280-005R	1	●	●	●	●	●	●	
30	SWITCH S12	1115-280-004R	1	●	●	●	●	●	●	
31	REAR PANEL	R-1019-198-1/08R	1	●	●	●	●	●	●	
32	BRACKETS	R-1019-153-1/08R	2	●	●	●	●	●	●	
33	COVER	R-1019-199-1/02R	1	●	●	●	●	●	●	
34	STICKER (WARNING)	2719-107-728R	1	●	●	●	●	●	●	
35	STICKER (LIFTING)	R-0010-279-1R	1	●	●	●	●	●	●	
36	EYE BOLTS	0653-313-011R	2	●	●	●	●	●	●	
37	LEFT SIDE PANEL	R-1019-216-1R	1	●	●	●	●	●	●	
38	STICKER (WIRING DIAGRAM)	R-0010-298-1R	1	●	-	●	-	●	-	
	STICKER (WIRING DIAGRAM)	R-0010-299-1R	1	-	●	-	●	-	●	
39	RIGHT SIDE PANEL	R-3019-184-1/02R	1	●	●	●	●	●	●	
40	HINGLES	D-3574-007-1/33R	2	●	●	●	●	●	●	
41	WIRE DRIVE DOOR	R-1019-217-1R	1	●	●	●	●	●	●	
42	LOCKS	0654-610-004R	2	●	●	●	●	●	●	

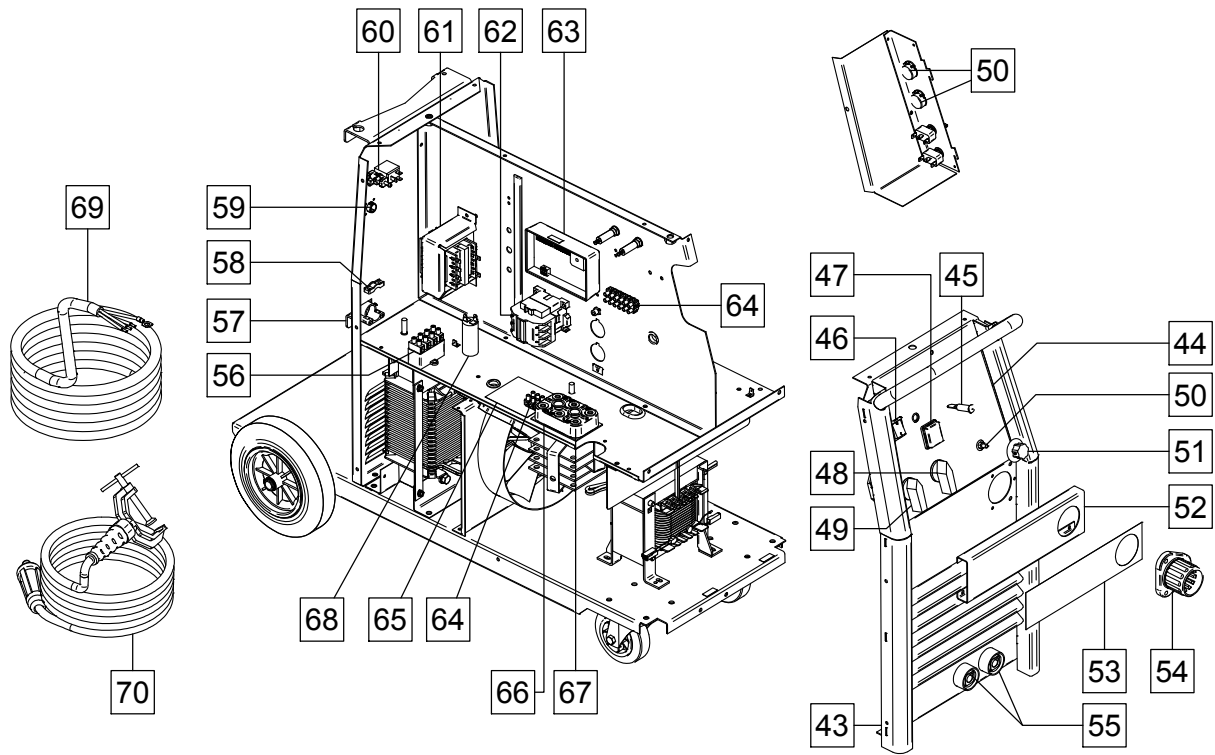

Figure E

Figure E: Machine Assembly - POWERTEC® 255C & 305C

Item	Description	Part Number	QTY	1	2	3	4	5	6	7
43	FRONT PANEL	R-3019-180-1/08R	1	●	●	●	●	●	●	
44	STICKER (FRONT PANEL)	R-0010-254-1R	1	●	●	●	●	●	●	
45	LAMP H1	0917-421-024R	1	●	●	●	●	●	●	
46	SWITCH S3	1115-270-019R	1	●	●	●	●	●	●	
47	BLACK FLAME SHIELD	1115-299-073R	1	●	●	●	●	●	●	
48	SWITCH S1	1115-260-167R	1	●	●	●	●	●	●	
49	SWITCH S2	1115-260-166R	1	●	●	●	●	●	●	
50	POTENTIOMETER R11,R12, R13	1158-113-304R	3	●	●	●	●	●	●	
51	KNOB	9ET10491R	1	●	●	●	●	●	●	
52	SHIELD	R-1019-205-1/02R	1	●	●	●	●	●	●	
53	STICKER (NAME PRODUCT)	R-0010-255-1R	1	●	●	-	-	-	-	
	STICKER (NAME PRODUCT)	R-0010-256-1R	1	-	-	●	●	●	●	
54	EURO SLEEVE	1361-599-708R	1	●	●	●	●	●	●	
55	SOCKETS X2, X3	C-2986-001-2R	2	●	●	●	●	●	●	
56	FILTER RC	0874-400-011R	1	●	●	●	●	●	●	
57	CABLE RELEIF	R-0010-258-1R	1	●	●	●	●	●	●	
58	CLAMP	1361-599-633R	1	●	●	●	●	●	●	
59	HOLE PLUG	1361-599-058R	1	●	●	●	●	●	●	
60	GAS SOLENOID	0972-423-005R	1	●	●	●	●	●	●	
61	TRANSFORMER T2	C-4244-374-2R	1	●	●	●	●	●	●	
62	CONTACTOR K1	1115-212-220R	1	●	-	-	-	-	-	
	CONTACTOR K1	1115-212-219R	1	-	●	●	-	●	-	
	CONTACTOR K1	1115-212-210R	1	-	-	-	●	-	●	
63	P.C. BOARD	Y024-4R	1	●	●	●	●	●	●	
64	TERMINAL BLOCK X13	1131-990-005R	6	●	-	●	-	●	-	
	TERMINAL BLOCK X12, X13	1131-990-005R	9	-	●	-	●	-	●	
65	STICKER (230/400V)	R-0010-221-1R	1	-	●	-	●	-	●	
66	PLATE	D-2731-731-1R	1	-	●	-	●	-	●	
67	TERMINAL BLOCK X11	1361-599-255R	1	-	●	-	●	-	●	
68	CAPACITOR C1	1158-121-045R	1	-	-	●	●	●	●	
69	POWER LEAD	D-5578-171-1R	1	●	-	●	-	●	-	
	POWER LEAD	D-5578-171-2R	2	-	●	-	●	-	●	
70	WORK LEAD	K14011-1	1	●	●	-	-	-	-	
	WORK LEAD	K14012-1	1	-	-	●	●	●	●	

Figure F, G: Wire Drive Assembly – POWERTEC® 255C & 305C

Item	Description	Part Number	QTY	1	2	3	4	5	6	7
	WIRE DRIVE ASSEMBLY	0744-000-160R	1	●	●	●	●	-	-	
71	FEED PLATE	0744-000-219R	1	●	●	●	●	-	-	
72	INLET GUIDE	0744-000-224R	1	●	●	●	●	-	-	
73	ADAPTER	0744-000-227R	1	●	●	●	●	-	-	
74	FIXING CAP	0744-000-216R	1	●	●	●	●	-	-	
75	METAL COVER	0744-000-218R	1	●	●	●	●	-	-	
76	PRESSURE ARM COMPL.	0744-000-221R	1	●	●	●	●	-	-	
77	SPRING PRESSURE ARM	0744-000-220R	1	●	●	●	●	-	-	
78	FIXING ARM COMPL.	0744-000-223R	1	●	●	●	●	-	-	
	WIRE DRIVE ASSEMBLY	0744-000-241R	1	-	-	-	-	●	●	
79	FEED PLATE	0646-233-002R	1	-	-	-	-	●	●	
80	INTERMEDIATE GUIDE	0646-233-023R	1	-	-	-	-	●	●	
81	INLET GUIDE	0646-233-025R	1	-	-	-	-	●	●	
82	LEFT PRESSURE ARM COMPLETE	0646-233-007R	1	-	-	-	-	●	●	
83	RIGHT PRESSURE ARM COMPLETE	0646-233-005R	1	-	-	-	-	●	●	
84	FIXING ARM COMPL.	0646-233-015R	2	-	-	-	-	●	●	
85	SPRING PRESSURE ARM	0646-233-013R	2	-	-	-	-	●	●	
86	AXIS PRESSURE ARM	0646-233-003R	2	-	-	-	-	●	●	
87	AXES OF DRIVE ROLL	0646-233-020R	2	-	-	-	-	●	●	
88	GEAR WHEEL MOTOR	0646-233-028R	1	-	-	-	-	●	●	
89	GEAR WHEELS ROOL	0646-231-090R	2	-	-	-	-	●	●	
90	COVER	0646-233-027R	1	-	-	-	-	●	●	
91	FIXING CAPS	0744-000-190R	2	-	-	-	-	●	●	
92	MOTOR	0744-000-229R	1	●	●	●	●	-	-	
	MOTOR	1111-722-046R	1	-	-	-	-	●	●	
93	WOODROF KEY	0646-231-102R	1	●	●	●	●	●	●	
94	EURO SOCKET COMPLETE	C-2985-006-2R	1	●	●	●	●	●	●	
95	OUTLET GUIDE	D-1829-066-4R	1	●	●	●	●	●	●	
96	SLEEVES	1361-599-720R	4	●	●	●	●	●	●	
97	SLEEVES	1361-599-565R	2	●	●	●	●	-	-	
	SLEEVES	D-1869-033-3R	2	-	-	-	-	●	●	
98	STICKER	2719-107-732R	1	●	●	●	●	●	●	

Miscellaneous Items (not shown in figure D, E, F, G)

Item	Description	Part Number	QTY	1	2	3	4	5	6	7
99	WIRING HARNESS (PRIMARY)	R-5041-176-1R	1	-	●	-	●	-	●	
100	WIRING HARNESS (PRIMARY)	R-5041-176-2R	1	●	-	●	-	●	-	
101	WIRING HARNESS (SECONDARY)	R-5041-177-1R	1	●	●	●	●	●	●	
102	WIRING HARNESS	R-5041-185-1R	1	-	-	●	●	●	●	
103	WIRING HARNESS	R-5041-186-1R	1	●	●	-	-	-	-	

S1	1	2	3	4	5	6	7	8	9	10
1-2	X									
3-4		X	X							
5-6				X	X					
7-8						X	X			
9-10	X	X								
11-12			X	X						
13-14					X	X				
15-16							X	X		
17-18	X	X								
19-20			X	X						
21-22					X	X				
23-24							X	X		

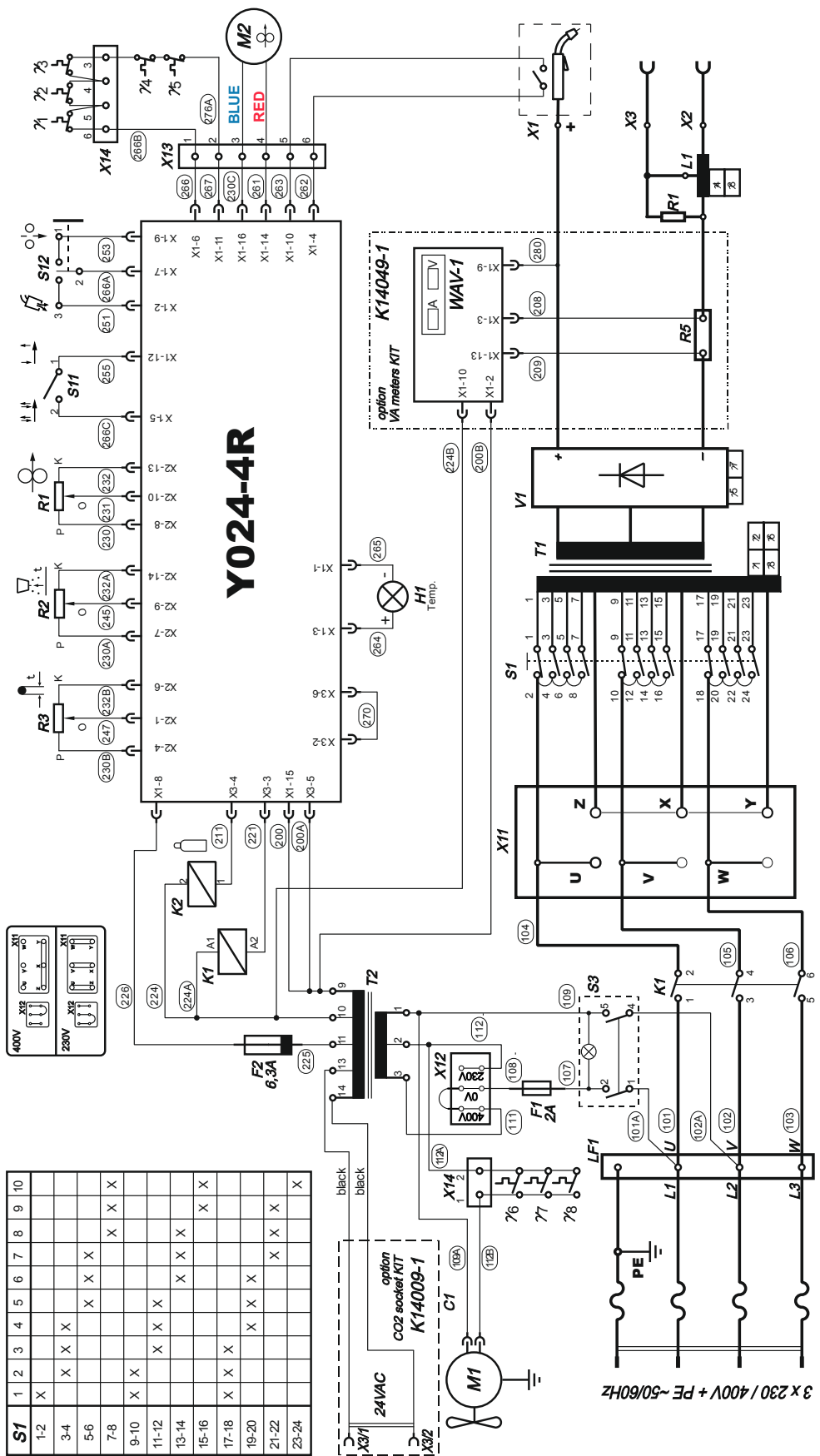

Y024-4R

POWERTEC® 205C 230/400V



S1		1	2	3	4	5	6	7	8	9	10	S2		A	B
1-2	X											1-2	X	X	
3-4		X	X	X								3-4		X	
5-6					X	X						5-6	X	X	
7-8							X	X				7-8		X	
9-10	X	X										9-10	X	X	
11-12			X	X	X							11-12		X	
13-14						X	X	X						X	
15-16									X	X				X	
17-18	X	X	X											X	
19-20				X	X									X	
21-22						X	X	X						X	
23-24									X	X	X			X	

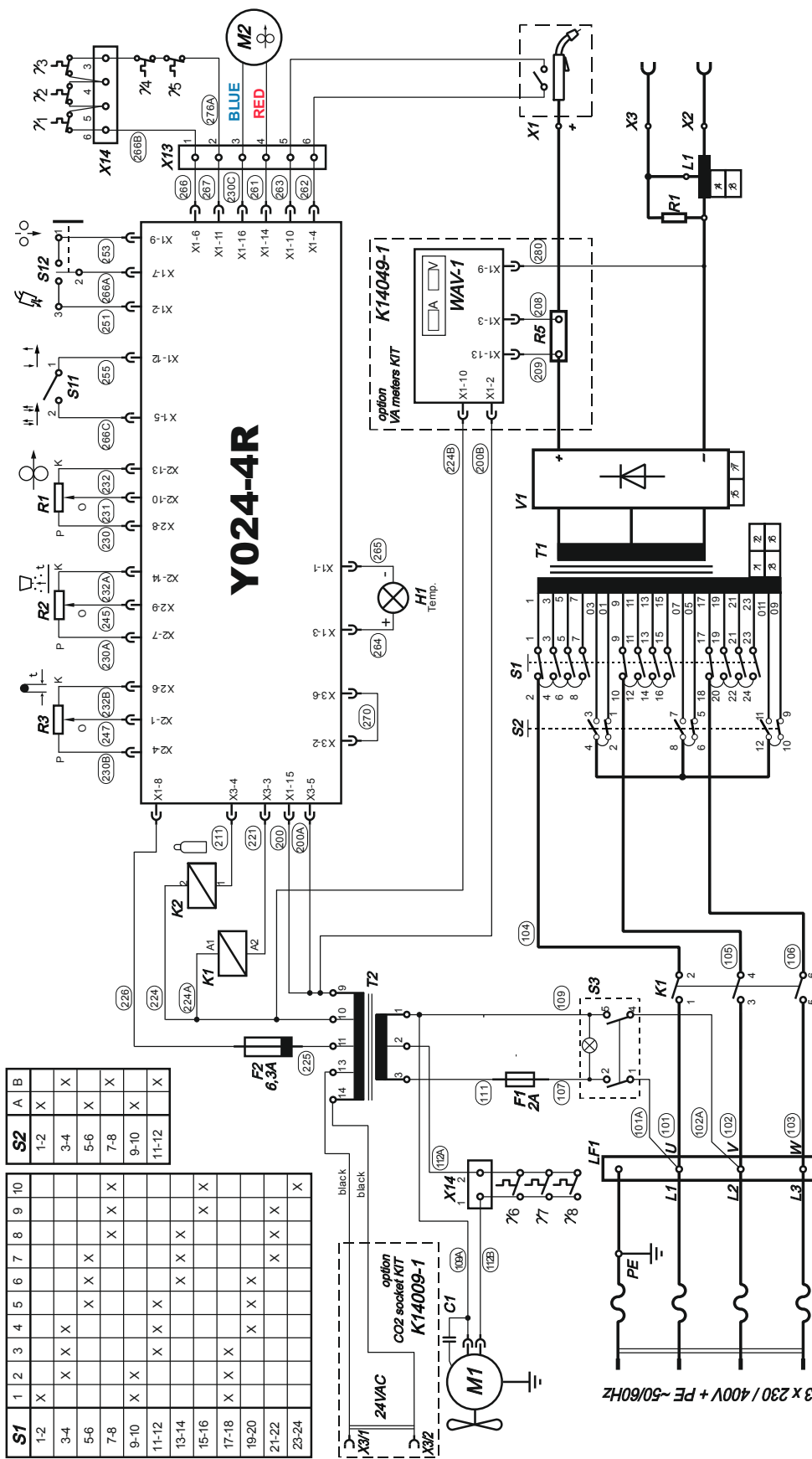

Y024-4R

POWERTEC® 255C 400V
 POWERTEC® 305C 400V



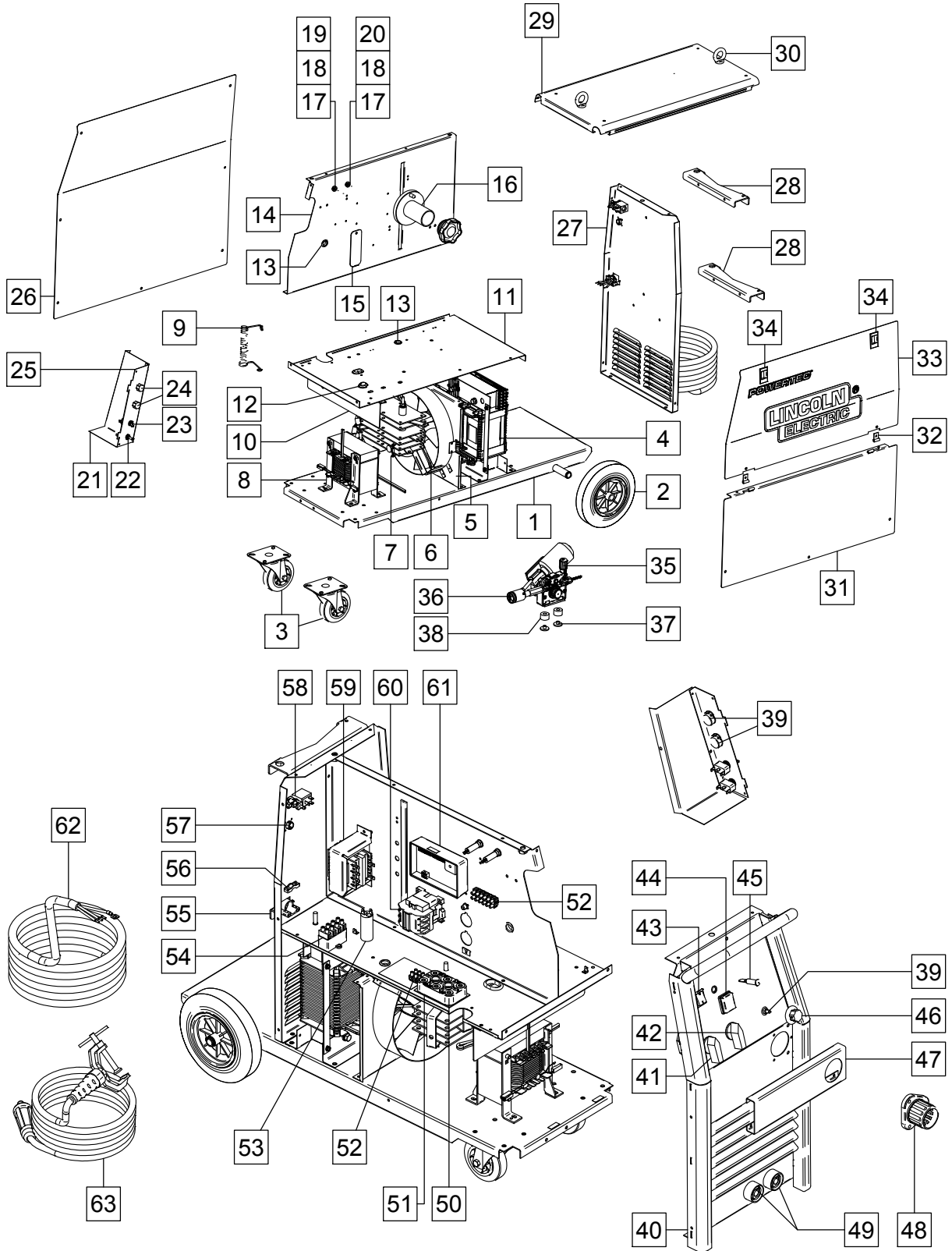

Description	Ref.	Recycle				ST				
		Fe	Al	Cu	Brass	Boards	Plastics	Liquid Cristal	External Electric Cables	Capacitors
BASE	1	X								
WHEELS	2, 3		X				X			
TRANSFORMERS	4, 59	X	X	X						
SUPPORT	5	X								
FAN	6	X							X	
RECTIFIER	7		X							
CHOKES	8	X		X						
RESISTOR	9	X								
SHIELD	10, 15, 21, 25, 47	X								
SHELF	11	X								
RUBBER CABLE BUSH	12, 13						X			
DIVIDER	14	X								
REEL HUB	16						X			
FUSE SOCKET	17						X			
FUSE CAP	18						X			
FUSE	19, 20	X								
SIDE PANEL	26, 31, 33	X								
SWITCHES	22, 23, 41, 42, 43	X			X		X			
KNOBS	24, 46						X			
LOCKS	34						X			
HINGLES	32	X								
REAR PANEL	27	X								
BRACKETS	28	X								
COVER	29	X								
EYE BOLTS	30	X								
POTENCIOMETERS	39	X								
GAS SOLENOID	58	X		X	X					
FRONT PANEL	40	X								
BLACK FLAME SHIELD	44						X			
WIRE DRIVE ASSEMBLY	35	X		X			X			
EURO SOCKET	36				X					
SLEEVES	37, 38						X			
LAMP	45			X			X			
EURO SLEEVE	48						X			
SOCKETS	49	X		X			X			
P.C. BOARD	61					X				
TERMINAL BLOCK	50, 52	X					X			
PLATE	51						X			
CAPACITOR	53									X
FILTER RC	54	X		X			X			
CABLE RELEIF	55						X			
CLAMP	56						X			
HOLE PLUG	57						X			
CONTACTOR	60	X		X			X			
POWER LEAD	62								X	
WORK LEAD	63								X	